

EVOLUTION OF THE TRADITIONAL MODEL.
ATTRACTIVE, FUNCTIONAL DESIGN. PROFESSIONAL 2-BOTTLE SYSTEM: REFRIGERATED, COMPACT,
MODULAR, EASY TO INSTALL (PLUG & PLAY).
MULTIPLE SYSTEMS CAN BE CONNECTED IN LINE.

N.B: the photo shows the model with the additional black panel



- Model available: eno one PLUS 2/r 2 bottles in line
- Wine conservation temperature: 6°C - 18°C 43°F-64°F
- Installation: "plug & play"
- Gas supply: food grade nitrogen E941 or food grade argon E938
- Doses: 1 free, 1 or 3 programmable
- Materials: stainless steel and black Gepax®
- Lighting: adjustable intensity LED
- Bottle positioning: self-centring system with gas spring piston lifting
- Refrigeration system: with thermoelectric module
- Dispenser settings: via central display
- Maintenance: warning light indicates when to clean the tap
- Accessories on request:
 - additional black or white side panels
 - modularity kit
 - spacer for low bottles
 - gas cylinder cover
 - divider panel for 1 white wine and 1 red wine
 - pressure regulators for cylinder with M11x1, M10x1, 5/8"-18UNF connection
 - handle with lock

BACKLIT KEYPAD

INTEGRATED SELF-CENTRING SYSTEM



FUNCTIONAL RED DISPENSER SPOUT

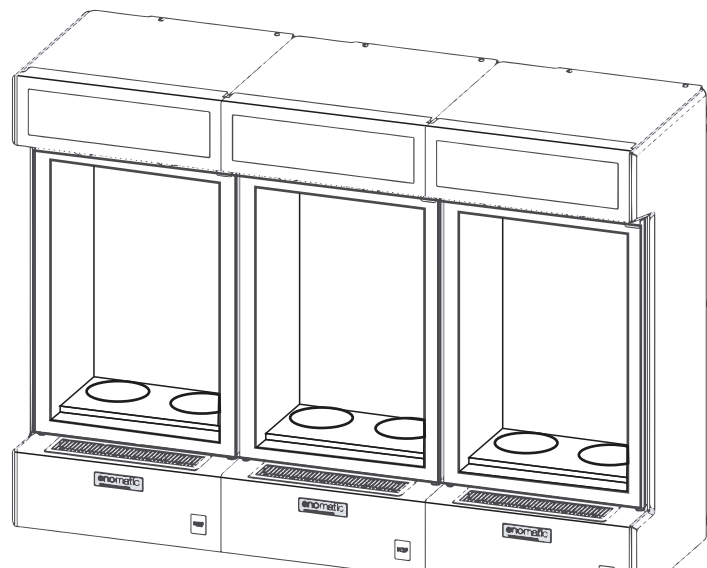

MODULARITY



model	L	H	P	weight	electrical requirements
eno one PLUS 2/r	27,6 cm 10,88 inch	59,7 cm 23,49 inch	35,1 cm 13,82 inch	12 kg	100-240 V 50-60 Hz 70 W (depending on the target market)